



Development of a hatch system for the determination of diffusible hydrogen in underwater welding

Desarrollo de un sistema de escotilla para la determinación de hidrogeno difusible en soldadura submarina

Rodrigo Fernandes-Lara¹, Andrés M. Moreno-Uribe^{2*}, Alexandre Q. Bracarense³

¹Ingeniero Mecánico, rodrigoflara@ufmg.br, Universidad Federal de Minas Gerais, Belo Horizonte, Brasil.

²Magister en Ingeniería Mecánica, andresmauriciomu@ufmg.br; [Orcid: 0000-0001-6717-0782](https://orcid.org/0000-0001-6717-0782), Universidad Federal de Minas Gerais, Belo Horizonte Brasil.

³Doctor en ingeniería metalúrgica y de materiales, queiroz@demec.ufmg.br; [Orcid: 0000-0001-7326-497X](https://orcid.org/0000-0001-7326-497X), Universidad Federal de Minas Gerais, Belo Horizonte Brasil.

How to cite: R. Fernandes-Lara, A.M. Moreno-Uribe, A.Q. Bracarense, "Development of a hatch system for the determination of diffusible hydrogen in underwater welding". *Respuestas*, vol. 25, no. 1, pp. 167-176, 2020.

Received on July 19, 2019; Approved on October 31, 2019

ABSTRACT

Keywords:

underwater welding,
diffusible hydrogen,
FCAW,
SMAW,
inspection hatch.

The design and implementation of hatch mechanism aims to optimize the development of underwater welding simulations performed in the Robotic, Welding and Simulation Laboratory. The project is part of the technologies upgrades applied to sciences of the sea, and will make it possible to evaluate the influence of welding parameters on SMAW and FCAW processes, especially as regards the content of diffusible hydrogen specimen welding in different depths. Due to the specifications imposed by the gas chromatography standards applied to welding, tests must be carried out at short intervals, which requires a fast process. This research will promote the evaluation of commercial electrodes and promote the development of new consumables.

RESUMEN

Palabras clave:

soldadura submarina,
hidrógeno difusible,
FCAW,
SMAW,
escotilla de inspección.

El diseño e implementación del mecanismo de escotilla, tiene como finalidad optimizar el desarrollo de simulaciones de soldadura ejecutadas en el Laboratorio de Robótica, Soldadura y Simulación. El proyecto hace parte de la actualización de tecnologías aplicadas a ciencias del mar, y posibilitará evaluar la influencia de los parámetros de soldadura en los procesos SMAW y FCAW, especialmente en lo que se refiere al contenido de hidrógeno difusible en cuerpos de prueba soldados en diferentes profundidades. Debido a las especificaciones impuestas por las normas de cromatografía de gases aplicadas a la soldadura, las pruebas deben desarrollarse en intervalos cortos, lo cual exige un proceso rápido. Esta investigación fomentará la evaluación de electrodos comerciales y promoverá el desarrollo de nuevos consumibles.

Introduction

Welding became a very important process in the manufacture and maintenance of components. One of its applications, underwater welding, is an area in continuous development due to the need to apply this technique in submerged structures. The increasing use of underwater wet welding (UWW) is due to the problems related to fatigue, corrosion and impacts of ships on marine structures in the off-shore and oil & gas industry [1]. This encourages companies in this field to be the main funders of research aimed at increasing the quality of welds made in aquatic environments [2].

The LRSS (Laboratory of Robotics, Welding and Simulation) of the Federal University of Minas Gerais

(UFMG) is recognized worldwide for its line of research in underwater welding, holding patents on consumables and being the only research center in Latin America that performs diffusible hydrogen tests for electrodes used in direct contact with water. In order to simulate the operating conditions of underwater welding, LRSS developed a hyperbaric chamber that allows the analysis of SMAW (Shielded Metal Arc Welding) and FCAW (Flux Cored Arc Welding) techniques. The pressure vessel has an approximate capacity of 0.5 m³ and was designed to withstand up to 2 MPa of pressure. To simulate the depth in the welding process, the chamber is filled with water by a hydraulic pump and the pressure is applied by injecting compressed air. To accomplish this task, mechanized and automated devices are used so that the process is carried out without the need for

*Corresponding author.

E-mail Address: andresmauriciomu@ufmg.br (Andrés M. Moreno-Uribe)



Peer review is the responsibility of the Universidad Francisco de Paula Santander.
This is an article under the license CC BY-NC-ND 4.0

human intervention. In this way, the hyperbaric chamber makes it possible to evaluate how process parameters e.g. current, voltage, polarity, type of coating and depth, interfere with the morphological and metallurgical characteristics of the weld seam. In this respect, an extremely important indicator in the underwater welding process is the content of diffusible hydrogen (Hdif), which directly influences the quality of the welded joints. To measure Hdif, it is necessary to meet the specifications imposed by the AWS D3.6M standard. Therefore, it was necessary to modify the access hatch to the hyperbaric chamber. The description of the modification, which will be dealt with in this article, aims to optimize the opening of the hatch to adjust the extraction time of the freshly welded sample within a given interval.

The underwater welding

process can be classified according to its operating conditions [3]:

Wet Underwater Welding (Wet Welding)
Dry Underwater Welding (Dry Welding)

In dry underwater welding, the repair is carried out isolated from the wet environment through a dry chamber. This metal structure allows the welder to perform a process equal to that executed in the atmosphere. Due to the dry environment, the most used welding techniques are GTAW (Gas Tungsten Arc Welding) and GMAW (Gas Metal Arc Welding), which produce high quality joints [4]. The dry chamber offers different advantages, provides more safety to the welder, helps to produce higher quality welds (including lower hydrogen content and better mechanical properties), facilitating in turn, the monitoring of the welded surface, as well as the use of non-destructive testing (NDT). Also, the great disadvantage of this process is related to the cost of assembly of the chamber (which can generate investments of up to US\$80,000 per welding project [5]) and the limited mobility of the welder due to its size.

On the other hand, wet underwater welding is performed in an environment directly exposed to the wet environment (Figure 1). The welder is immersed and performs his work in an analogous way to what is done in the atmosphere, having a great freedom of movement, which makes this technique more efficient and economical [6]. It should be noted that water has a great influence on the

process: it makes the welding operation more difficult and causes instability of the arc, affecting the mechanical properties of the weld seam due to the hydrogen content, compared to the welds made in air, and can thus present cracks [7]. Although it is a faster and cheaper process, the direct operation in the aquatic environment worsens the visibility, and therefore the inspection of the welded surface.



Figure 1. Welder performing the underwater wet welding process [4].

Welds executed in an underwater environment tend to present degradation of mechanical properties compared to those executed in air [8], since exposure to this type of environment increases the probability of

- Porosity.
- Hydrogen-induced cracking.
- Loss of alloying elements.
- Formation of inclusions.

Diffusible hydrogen

The quantification of diffusible hydrogen in welded joints is extremely important for the study of the influence of process parameters and the evaluation of consumables, especially those executed in underwater environments, since it is a surrounding with high hydrogen content, it is responsible for the appearance of pores and cracks. During the welding process, the hydrogen present in the ambient humidity is in direct contact with the electric arc and is absorbed by the melting pool. While cooling occurs, some of the hydrogen decomposes by diffusion.

However, some of it is retained in the base metal and in the HAZ (Heat-Affected Zone) [9]. Therefore, the combination of diffusible hydrogen with the fragile microstructure promotes cracking.

According to [10], hydrogen cracking is promoted by the following factors:

- High concentration of diffusible hydrogen.
- Residual stress.
- Susceptible microstructure (Martensite)
- Low temperatures (between -100 and 100 °C).

The gas chromatography process is used to analyse the content of diffusible hydrogen present in the welds. The method is used to determine the composition of a mixture of volatile substances. The sample to be analysed is introduced into a flow, called a carrier gas, which passes through a capsule containing the stationary phase in which the gas separation takes place. In the case of diffusible hydrogen analysis, the freshly welded and properly cleaned sample is inserted into a capsule with a suitable inert gas. It is then heated so that the hydrogen contained in the weld metal can be released into the inert atmosphere by diffusion. The released hydrogen is transferred to the chromatograph by means of capsules for measurement (Figure 2).



Figure 2. Chromatography and capsule used in the hydrogen diffusible test in the LRSS

diffusible hydrogen in welds made in an underwater environment, the process is carried out according to ASTM E260-96: Standard Practice for Packed Column Gas Chromatography. The standard determines that the entire post-weld process, from sample extraction from the pressure chamber to insertion into the chromatograph capsules, should not exceed 2 minutes, counted from the extinction of the electric arc.

To meet the time criteria set by the standard, the hyperbaric chamber of the LRSS was subjected to changes in its opening mechanism. Also, in order to further optimize the opening time of the tank and thus allow proper sample preparation to be done more meticulously, promoting more assertive results, a quick opening hatch project was implemented.

Preliminary considerations

In accordance with the conditions established by the standard for hydrogen diffusion tests in underwater welding and seeking to optimize access to the interior of the hyperbaric chamber, the project took into account the following factors:

- a) Optimize the opening and closing of the tank;
- b) Support the depth simulation pressure;
- c) Promote the watertightness of the system.

As already described in this article, the need to optimize access to the interior of the hyperbaric tank aims to limit hydrogen testing under chromatography standards, which require that the entire process after welding, from extraction of the submerged sample to cleaning and insertion into the chromatography capsules, take place within 2 minutes. In addition, the ease of opening and also closing the chamber, decreasing the time required for each welding process, which increases the productivity of the researcher.

The simulated depth in the hyperbaric chamber is achieved by injecting compressed air into a small column of water. The water is pumped to cover the sample, part of the coated electrode and the mechanized welding system, then compressed air is injected. In this way, the designed hatch must withstand the pressures to which the system will be subjected. The chamber was designed in the early 2000's to withstand a simulated depth of 200 meters (2 MPa pressure) (Figure 3). However, although most

In order to use this technique for the measurement of

research is only interested in studying the phenomena up to a maximum depth of 50 meters, at which most commercial underwater welding is done, the inspection hatch was developed to withstand up to 100 meters (1 MPa). It should be noted that the purpose of generating airtightness is essential for any pressure vessel cover and, in this project, it influenced the choice of materials for its manufacture.



Figure 3. Pressure vessel modified in 2012 by [11], for wet welding simulation under water adapted for the extraction of samples for the measurement of the diffusible hydrogen content.

Considering the needs of the new project, the change was mainly inspired by the hatches of the fermentation tanks (Figure 4). These mechanisms are interesting because they withstand high pressures and, more importantly, are easy to open and close. Widely used in the liquor industry, manhole doors are metal structures, generally elliptical in shape, with dimensions slightly larger than the tank access opening. Manhole doors have a threaded bar on their external face and are articulated by a rotating arm on the tank surface. They are also covered with a rubber band to facilitate sealing.

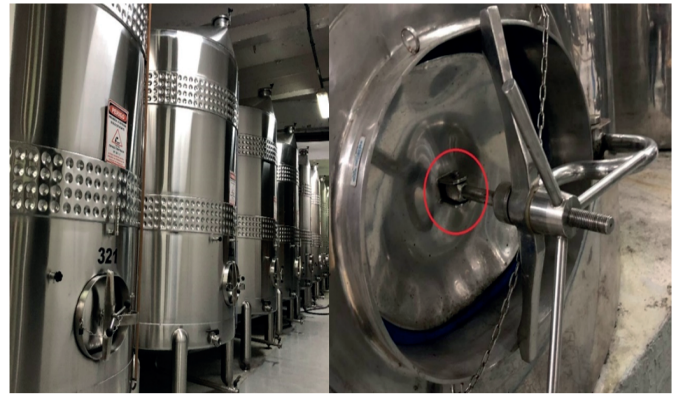

Figure 4. (left) Fermentation tanks used in the wine industry in the region of Rio Grande do Sul (RS) - Brazil (right) Fermentation tank hatch. The hinge is detailed (red).

Hatches generate rigidity by turning a nut on the threaded bar. The movement presses the rubber band against the tank, which generates the seal. As can be seen in figure 4, the hatches can be placed on the inside or outside surface of the tank.

When positioned on the inside, the hatch is accompanied by a shaft that is crossed by the threaded bar and located on the sides of the access hatch. When the nut is moved to close the system, its movement towards the surface of the hatch is contained by the shaft, which generates an axial force directed out of the chamber. This compresses the rubber band of the hatch against the inner surface of the tank. This model, being internal, has the advantage that the pressure helps the sealing of the chamber.

In cases of elliptical-shaped inner hatches, it is common to have mechanisms that allow the lid to slide in and out of the tank. This mechanism can be a bearing between the hinged arm and the threaded bar and a hinge that fixes the bar to the inspection door, or a device at the point of connection of the arm to the bar that allows the rotation of the hatch, both in relation to the axis of the arm and in relation to the axis of the bar. These mechanisms allow the initial installation of the system without the need for another access entrance and its removal for cleaning or inspection (Figure 4).

Analyzing several hatches of fermentation tanks and studying the objectives for their different formats, it was necessary to take into account the conditions of the hyperbaric chamber present in the LRSS:

a) Tests in the laboratory can simulate depths of up to 100 meters by injecting compressed air, i.e. 1 MPa of pressure. In this sense, an internal hatch would be more interesting for two reasons. Firstly, due to the high pressure inside, it is advantageous that it helps to seal the tank, so only a small initial adjustment of the nut (or handwheel) is necessary. And secondly, to withstand such internal pressure, a hatch on the outside of the tank must have a large threaded bar, which is not economically suitable.

b) After cutting the old access hatch to the hyperbaric tank, it was observed that it had a circular shape (Figure 5). Therefore, it would not be possible to use the advantage of an internal elliptical hatch to be removed from the access opening. In this case, the design does not have mechanisms to allow the system to move relative to the arm and also not relative to the shaft. For the initial installation, the side opening of the tank will be used, so the design should have two parts: one containing the hatch and the threaded bar, and the other containing the articulated arm. The way in which each section is coupled will be demonstrated in the development of this article.

(c) The interior of the hyperbaric tank is a cylindrical surface. Thus, it would be possible to carry out an internal hatch design in two ways: the first would be to weld a steel cylinder into the upper access opening of the chamber, so that the lower edge of this cylinder is below the internal surface of the tank, as described by [12]. This option, in addition to requiring welding, would reduce the internal space available for experiments. In the second option, the upper face of the hatch must follow the internal curvature of the hyperbaric chamber. In this case, the last one was chosen because, although it requires a calendaring process to configure the inspection hatch, it would be easier to implement, would give a larger contact area and would have a favorable geometry to support the stresses.

After this analysis, taking into account the objectives that the project should perform and the conditions of the hyperbaric chamber, it was concluded that an internal hatch would be developed with a geometry that would adapt to the interior of the tank.



Figure 5. Old hyperbaric chamber hatch (left), Upper access opening resulting from flange removal (right).

Design

The design for the alteration of the LRSS hyperbaric chamber was modeled in CAD taking into account the above considerations, and Figure 6 presents in detail the section view of the upper opening. The elements involved are described below:

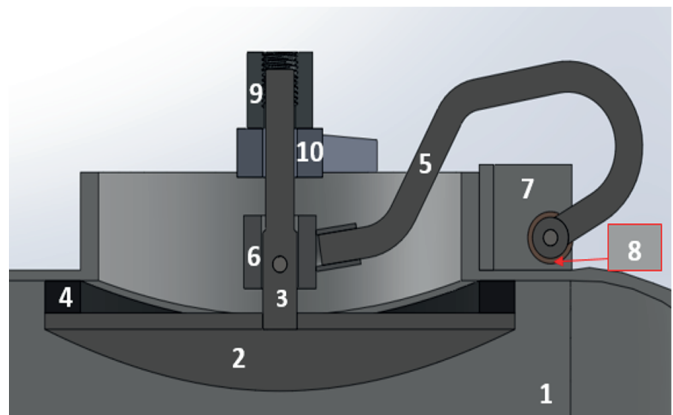

Figure 6. Section view with details of the internal hatch model

Description of the elements

1. Hyperbaric chamber
2. Hatch door

This component is designed to fit the interior surface of the tank. It is manufactured from the calendaring of a 10 mm thick ABNT 304 stainless steel plate Figure 7.

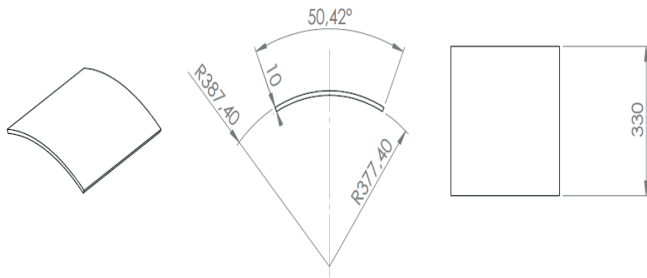

Figure 7. Section view with details of the internal hatch model

After undergoing the calendaring process so that the outer radius of the face coincides with the inner radius of the chamber access, the plate was cut and machined. The cut, in the top view, would be a radius of 40 mm (larger than the radius of the top access opening), which ensures a sufficient area to withstand the stresses imposed on the hatch by the internal pressure during the experiments. As this was a curved section, it was necessary to use a water cutting machine that works in 3 axes. Water cutting was necessary, as similar processes such as oxyfuel cutting could result in deformation and residual stresses in the part, which would affect the geometry of the inspection hatch. Finally, a hole was drilled in its center to be connected to the threaded bar.

During the design phase, static charge simulations were performed to validate the hatch. The forces applied to the inspection hatch are the weight (applied at the center of mass) and the force provided by the pressure inside the tank due to the compressed air acting on the bottom and side faces of the hatch (1 MPa). The only area of attachment chosen was the surface of the hatch that runs under the tank hull in a radius of 40 mm, so this area was considered to be attached to the inner face of the tank. A solid mesh with 9288 high order quadratic type elements was used for the simulation, for a total of 16329 nodes. For the particular case of the Von-Mises stress calculation, an index that represents the equivalent stress acting on the differential elements of the model and which is compared with the elastic limit stress of the material, the color palette in Figure 8 shows a maximum value of 118 MPa, well below the elastic limit of the hatch material (approximately 207 MPa). The results are shown below and it is concluded that, in accordance with the characteristics described, the project has been validated. A minimum safety factor of 2 was calculated from the hatch's stress layout, which validates the design in relation to the constraints and loads imposed.

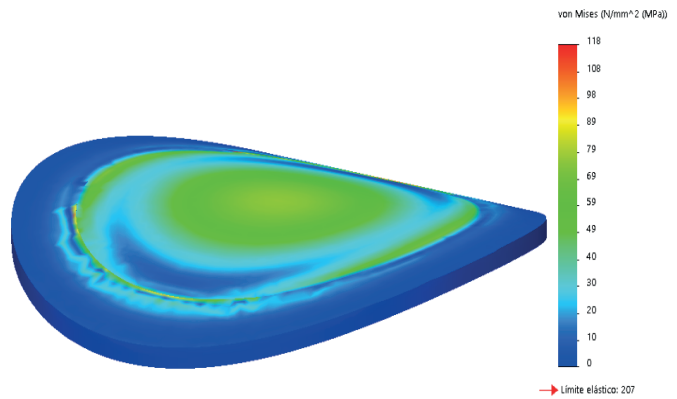

Figure 8. Von Mises voltage resulting from the hatch simulation.

3. Threaded bar

The threaded bar was manufactured from a 25.4mm diameter, 300mm long shaft (Figure 9), of the same material as the inspection gate, ABNT 304 stainless steel.

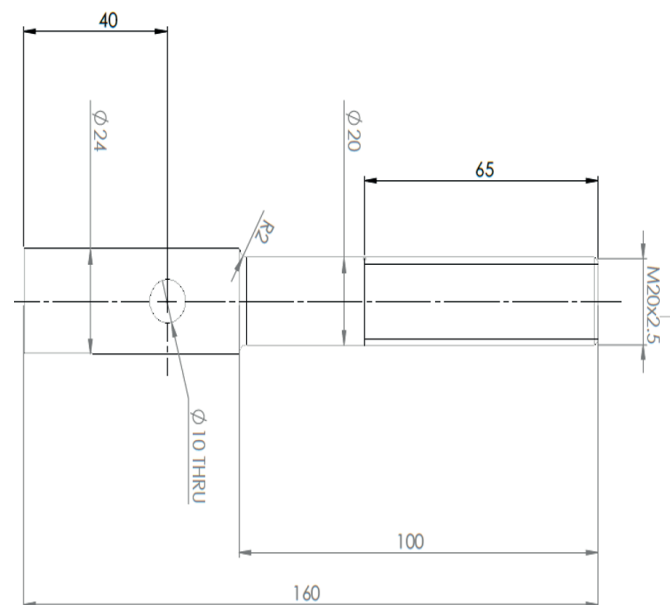

Figure 9. Turning plan of the threaded bar.

The machining of the threaded bar generated an axis with two different radius sections. The upper section was threaded to the M20x2.5 dimension, and the lower section was machined to fit the center hole of the hatch with 0.5mm clearance. A hole was also created in the lower part to allow the bar to be coupled with the hinged arm.

After the inspection hatch and the threaded bar were manufactured, the two were welded together in this manner: the bar was positioned in the opening made in the center of the hatch, so that the lower faces of both parts coincided, aligning the axis of the opening and the longitudinal axis of the bar and the hatch, respectively. Finally, two weld beads were made with an AWS E308 electrode.

4. Rubber band

A low density rubber with a square profile of 25 mm was used (Figure 10). This component has the function of correcting small inconsistencies between the upper face of the hatch and the inner face of the hyperbaric chamber, also helping in the sealing.



Figure 10. Manufactured inspection hatch

5. Articulated arm

The hinged arm has the function of moving the hatch between its closed and open position (Figure 11). This component was manufactured by bending an ABNT 304 stainless steel shaft and its design took into account two points:

Dimension of the hatch: as it is a rotating support in relation to a fixed point in the hyperbaric chamber, the length of the articulated arm must be greater than the radius of the hatch plus the vertical distance from the center of the fixed point of the arm to the internal face of

the tank. This ensures that the inspection door opening conforms to the dimensional requirements.

Access Dimension: The radius of the hinged arm should allow the hatch to be fully opened without interference with the upper access opening. To determine the position of the hatch when open, simply align the center of mass of the inspection door vertically with the center of the arm attachment point.

6. Arm Bushing

This part was manufactured by machining an ABNT 304 stainless steel bar and welding a tube of the same material. It also has an elongated hole in its cylindrical face. The function of this bushing is to make the connection between the arm and the threaded bar of the hatch by means of a screw that crosses the two components. It should be noted that, the elongated hole was made because it allows the vertical movement of the hatch even when the arm is stationary, this facilitates the assembly and, above all, allows the vertical movement of the inspection hatch, when the rubber covering it is deformed by applying internal pressure due to compressed air.

7. Arm fixing bracket

Made of carbon steel and welded to the upper opening cylinder and the hull of the hyperbaric chamber. By means of a bolt, it is used as a fixing point for the articulated arm.

8. Washers

Two copper washers were manufactured and inserted between the articulating arm and its fixing bracket to reduce friction between the components and eliminate possible play.



Figure 11. Articulated arm and manufactured washers

9. Nut and flywheel

This component is a nut of a size that matches the threaded bar and has been welded to a handwheel ([Figure 13](#)), making it easier to adjust.

10. Stem

This component was manufactured by welding two pieces (parallelepiped-shaped) to a cylinder with a central hole ([Figure 12](#)). It allows the threaded bar to be inserted into it and the nut to be inserted from the top. Its function is to contain the descent of the nut after tightening, which creates a force on the hatch upwards, compressing the rubber against the inner face of the hyperbaric chamber, thus generating the seal of the system.



Figure 12. Rod and handwheel with welded nut

[Figure 13](#) below shows the final assembly of each coupled and installed assembly, and an overview of the hyperbaric chamber:



Figure 13. Modifications of the LRSS hyperbaric chamber (left), overview of the LRSS hyperbaric chamber (right)

Implementation

1. Closing the tank:

- 1.1. Retracting the hatch to the vertical position;
- 1.2. Pass the rod hole through the thread;
- 1.3. Insert the handwheel and turn until the rubber is slightly compressed;
- 1.4. Start the air pressure injection;
- 1.5. As the internal pressure increases, the hatch will move upwards compressing the rubber and leaving the handwheel free;
- 1.6. Remove the rod and the handwheel so as not to generate any faults during decompression of the tank.

2. Open the tank:

- 2.1. Start the decompression of the tank by the valve
- 2.2. Hold the hatch manually when the pressure approaches 0,1 MPa;
- 2.3. After the total is complete, the hatch shall start to descend;
- 2.4. Lower the hatch manually to the horizontal position.

Conclusions

The alteration of the opening hatch of the hyperbaric chamber of the LRSS had as main objective to optimize the access to its interior, and thus to make possible the research works in the area of the submarine welding, specifically in the use of the gas chromatography for the analysis of the content of diffusible hydrogen. Likewise,

and after the implementation of the mechanism and the performance of a series of tests, it was possible to analyze the time to seal and open the tank.

Initially, during the closing of the hyperbaric chamber, the rod and the handwheel with the nut were used to compress the rubber, in order to inject compressed air. Although this process was already considerably fast, it was realized that these two components were no longer necessary: because it is possible to start the injection of compressed air prematurely and to manually position the hatch by compressing the rubber band. As soon as the rubber creates a partial seal, the internal pressure is sufficient to act on the inner face of the hatch and create the total seal in the system. In addition to simplifying the process, the non-use of the rod and handwheel optimized the closing time of the chamber.

There is another change in the opening process: the time needed for the hatch to open depends only on the air output. Thus, the use of a larger diameter exhaust valve resulted in faster depressurization in the tank when operated, reducing the time needed to enter the tank after an experiment.

The tank changes have fulfilled their main function and now contribute to the practice of gas chromatography tests applied to welds made in an underwater environment.

References

- [1] [R. R. Marinho, M. T. P. Paes, E. C. P. Pessoa, et. al., “Perspectivas e Desafios para Aplicação da Soldagem Subaquática Molhada na PETROBRAS”, *Rio Welding*, 2014. \[En línea\]. Disponible en: <https://docplayer.com.br/30687506-Perspectivas-e-desafios-para-aplicacao-da-soldagem-subaquatica-molhada-na-petrobras-trabalho-a-ser-apresentado-durante-a-rio-welding-2014.html>.](#)
- [2] [B. Silvestre and P. Dalcol, “Geographical proximity and innovation: Evidences from the Campos Basin oil & gas industrial agglomeration-Brazil”, *Technovation*, vol. 29, no. 8, pp. 546-561, 2009.](#)
- [3] [M. Joshi, D. Rautela, R. Chauhan and S. Suyal, “Scrutinize Research on Underwater Welding Process: A Review”, *IOSR Journal of Mechanical and Civil Engineering*, vol. 13, no. 5, pp. 74-78, 2016.](#)
- [4] [C. E. Grubbs, A. E. Bertelmann, S. Ibarra, et. al., “Welding Handbook Material and Applications-Part 1”, *Estados Unidos: AWS*, 1996.](#)
- [5] [K. Verma and H. K. Garg, “Underwater Welding-Recent Trends and Future Scope”, *International Journal on Emerging Technologies*, vol. 3, no. 2, pp. 115-120, 2012.](#)
- [6] [C. E. Grubbs and O. W. Seth, “Underwater Wet Welding With Manual Arc Electrodes”, *ASCE National Water Resources and Ocean Engineering Convention*, San Diego, Estados Unidos, 1976.](#)
- [7] [A. Uribe, A. Q. Bracarense, E. Pessoa and V. R. Santos, “Influência da Polaridade Sobre a Estabilidade do Processo de Soldagem Subaquática Molhada com Eletrodo Revestido”, *Soldagem & Inspeção*, vol. 22, no. 4, pp. 429-441, 2017.](#)
- [8] [A. M. Pope, S. Liu, J.C.G. Teixeira, et. al., “Use of Nickel to Improve the Mechanical Properties of High Oxygen Underwater Wet Welds”, 3th OMAE/ *International conference on offshore mechanics and arctic engineering*, Copenhagen, Denmark, 1995.](#)
- [9] [W. C. D. Silva, A. Q. Bracarense and E. C. P. Pessoa, “Efeito da profundidade de soldagem no hidrogênio difusível de soldas molhadas”, *Soldagem & Inspeção*, vol. 17, no. 4, pp. 298-305, 2012.](#)
- [10] [M. Rowe and S. Liu, “Recent developments in underwater wet welding”, *Science and Technology of Welding and Joining*, vol. 6, no. 6, pp. 387-396, 2013.](#)

- [11] [W. C. D. Silva, L. F. Ribeiro, A.Q. Bracarense and E. C. P. Pessoa, “Effect of the Hydrostatic Pressure in the Diffusible Hydrogen at the Underwater Wet Welding”, *31st Internacional Conference on Ocean, Offshore and Arctic Engineering, volume 6: Materials Technology, Polar and Arctic Sciences and Technology, Petroleum Technology Symposium, Rio de Janeiro, Brazil, 2012.*](#)
- [12] [A. M. M. Uribe, A. Q. Bracarense, E. C. P. Pessoa, et. al., “Metodología de Diseño de una Escotilla de Inspección para Recipientes a Presión”, *Investigación e Innovación en Ingenierías, vol. 5, no. 1, pp. 8-23, 2017.*](#)